

OPERATION & INSTALLATION MANUAL

BAPTISTRY HEATER AND CONTROL SYSTEM



CR6000 & CR6000T SERIES 5.5KW

CR6005 & CR6005T SERIES 11.0KW



CHURCHRITE – PO BOX 513 Rocky Mount, VA 24151

TABLE OF CONTENTS

IMPORTANT SAFETY INSTRUCTIONS	3
PRODUCT FEATURES	6
INSTALLATION/OPERATING CONSIDERATIONS	7
ELECTRICAL INSTALLATION	8
COMPONENT CONNECTIONS	9
PLUMBING DIAGRAM	10
SYSTEM INTERFACE MODULE	11
PLUMBING TIPS	12
SKID LAYOUT/SYSTEM START-UP	13
EQUIPMENT DESCRIPTION	14
OPERATION	16
PROBLEM SOLVING	18
WARRANTY	19

CHURCHRITE PART NUMBERS

CR PART NUMBER	DESCRIPTION
CR-6005	11KW HEATER SYSTEM
CR-6000	5.5KW HEATER SYSTEM
CR-6005T	11KW HEATER SYSTEM W/TIMER
CR-6000T	5.5KW HEATER SYSTEM W/TIMER
48-0142	DRAIN CONTROL KIT
48-0140	WATER FILL/LEVEL KIT
48-0141C	WATER LEVEL KIT
48-0143	WATER FILL KIT
48-0042	SYSTEM INTERFACE MODULE
34-0038D25-D	REMOTE CONTROL KIT
48-0140A	WATER FILL/LEVEL ONLY

IMPORTANT SAFETY INSTRUCTIONS

WHEN INSTALLING AND USING THIS EQUIPMENT, BASIC SAFETY PRECAUTIONS SHOULD ALWAYS BE FOLLOWED, INCLUDING THE FOLLOWING:

READ AND FOLLOW ALL INSTRUCTIONS

INSTALLATION CONSIDERATIONS

1. A bonding lug has been provided on the outside of the equipment system electrical controls box. This lug permits the connection of a No. 8 AWG solid copper bonding conductor between the equipment system and all other electrical equipment and exposed metal in the vicinity, as may be needed to comply with local regulations.
2. The equipment system must be installed to provide adequate drainage, and to prevent water from entering the electrical equipment area. When installing the equipment system indoors, the floors and structures beneath the installation area must be protected against water run off.
3. The electrical supply for permanently connected equipment systems that do not have an internal disconnect must include a suitably rated switch or circuit breaker to open all ungrounded supply conductors to comply with section 422-20 of the (NEC) National electric code, ANSI/NFPA 70-1987. The disconnect means must be readily accessible to the tub occupant but at least 5 feet (1.5m) from the tub water. The electrical supply for permanently connected equipment systems must also include a suitably rated ground fault circuit interrupter (GFCI) to comply with article 680-42 of the national electric code, ANSI/NFPA 70.
4. **DANGER** - risk of injury (For cord and plug connected units only). Do not use an extension cord. The equipment system must be located close enough to the electrical outlet that an extension cord shall not be required. Use of an extension cord will seriously degrade the equipment system performance, and can create a serious electrical hazard.
Never bury the power cord.
To reduce the risk of electric shock, replace a frayed or damaged power cord immediately. Connect only to a grounded, grounding type receptacle rated at 120 volts, 20 amperes. Never modify the attachment plug to fit other than a grounded, 120 volt, 20 ampere receptacle.
5. **DANGER - RISK OF ELECTRIC SHOCK.** Do not permit any electrical such as a light, telephone, radio, or television, within 5 feet of the tub.
6. **DANGER** - to reduce the risk of injury, do not permit children to use this product unless closely supervised at all times.
7. **WARNING - RISK OF CHILD DROWNING.** Exercise extreme caution to prevent unauthorized access by children. To avoid accidents, ensure that children cannot use the tub unless they are closely supervised at all times.

8. **WARNING - TO REDUCE THE RISK OF INJURY**

- A. The water in a tub should never exceed 100f (38c). Before entering the tub the user should measure the water temperature with an accurate thermometer, since the tolerance of water temperature-regulating devices may vary as much as +/- 5 f (3c). A water temperatures of 100f (38c) is considered safe for a healthy adult. Lower water temperatures are recommended for extended use (exceeding 10-15 minutes) and for young children.
 - B. Since excessive water temperatures have a high potential for causing fetal damage during the early months of pregnancy, pregnant or possibly pregnant women should limit tub water temperatures to 100f (38c).
 - C. The use of alcohol, drugs, or medication before or during tub use may lead to unconsciousness with the possibility of drowning.
 - D. Persons suffering from oCRity or with a medical history of heart disease, low or high blood pressure should consult a physician before using a hot tub.
 - E. Persons using medication should consult a physician before using a hot tub since some medication may induce drowsiness while other medication may affect heart rate, blood pressure, and circulation.
 - F. Because occasional users of the tub may not be aware of all of the potential risks associated with tub usage, they should be made aware of these important safety features.
 - G. The very young, or aged, those with illness, heart conditions or under doctor's care should not use the tub unattended. Infants should not be permitted in water temperatures more than 100f.
 - H. Prolonged immersion in water that is warmer than normal body temperature can result in a dangerous condition known as HYPERTHERMIA. The causes, symptoms, and effects of hyperthermia may be described as follows: hyperthermia occurs when the internal temperature of the body reaches a level several degrees above the normal body temperature of 98.6f. The symptoms of hyperthermia include dizziness, fainting, drowsiness, lethargy, and an increase in the internal body temperature. The effects of hyperthermia include: (1) unawareness of impending hazard, (2) failure to perceive heat, (3) failure to recognize the need to exit the hot tub, (4) physical inability to exit the hot tub, (5) fetal damage in pregnant women, and (6) unconsciousness resulting in a danger of drowning. **WARNING:** the use of alcohol, drugs, or medication can greatly increase the risk of fatal hyperthermia.
9. **DANGER** - to reduce the risk of injury to persons in the tub, never remove, or alter in any way, the grates or covers on the suction fittings in the tub. Never operate the equipment system if the grates or covers on the suction fittings are broken or missing.

The water should always flow freely from the hydrotherapy jets within the tub. Any blockage or restriction of water flow by persons or objects may damage the system components, create an electrical shock hazard, and/or cause water damage to the surrounding area. To avoid damage to the pump and heater, the equipment system must never be operated unless the tub is filled with water to the operating level.

10. **WARNING** - the equipment system may be equipped with a ground fault circuit interrupter (GFCI), mounted on the electrical control box. This GFCI protects against electrical shock hazard by sensing electrical fault conditions and interrupting the electric power applied to the equipment system.

Before each use of the tub the GFCI, if provided, should be tested in the following manner: Turn electric power on, Push the test button. The reset button should pop outward, indicating that the GFCI is functioning properly. Push the reset button all the way in, restoring electrical power to the equipment system. If the reset button does not pop outward when the test button is pushed, a loss of GFCI protection is indicated. Should this occur, immediately disconnect electrical power from the equipment system, and discontinue use of the tub until a qualified technician has identified and corrected the problem.

11. **DANGER** - risk of electrical shock. Install at least 5 feet (1.5m) from all metal surfaces. A tub may be installed within 5 feet of metal surfaces if each metal surface is permanently connected by a solid copper conductor attached to the wire connector on the control box that is provided for this purpose. A pressure wire connector is provided on the control box to permit connection of a minimum No. 8 AWG (8.4mm) solid copper bonding conductor. The bonding conductor should not be smaller the service conductors supplying the equipment. Connect this point to any metal enclosures of electrical equipment, metal water pipes, or conduit within 5 feet (1.5m) of the unit as needed to comply with local requirements.

SAVE THESE INSTRUCTIONS

PRODUCT FEATURES

1. **GROUND FAULT CIRCUIT INTERRUPTER** – This device is required for portable tubs as specified in the national electrical code article 680. The GFCI is designed to protect against potential electrical shock hazard should a ground fault occur.
2. **THERMOSTAT** - The thermostat regulates the water temperature of your tub.
3. **TIMECLOCK (Optional)**: Provides timer control over heating and filtering cycles
4. **PUMP RECEPTACLE** – Connect pump here.
5. **POWER AIR SWITCH** – Turns the system on and off
6. **SAFETY LIGHT CIRCUIT** – 120V hot output for 12V light circuit
7. **SANITIZER CIRCUIT** – Provides a 120V output when pump is running for a water sanitizer
8. **HIGH LIMIT** - A safety switch that will shut the heater off if the temperature within the heater reaches a non-adjustable limit. Push to reset.
9. **SYSTEM INTERFACE MODULE RECEPTACLE** – Provides Auto-Fill and Auto-Drain function. Auto-Fill Control (PT# 48-0042)
10. **REMOTE CONTROL RECEPTACLE**: Provide remote thermostat control over the system.
11. **HEATER ASSEMBLY** - Thermostatically controlled and equipped with a high-limit safety shut off.
12. **ROCKER SWITCH**: Determines operation of the timeclock.
13. **PLUMBING HEADER ASSEMBLY** – Connects the pump to the heater
14. **PUMP ASSEMBLY** – Pumps water to and from the baptistry
15. **BASE** – ABS base for mounting equipment

Figure 1.0

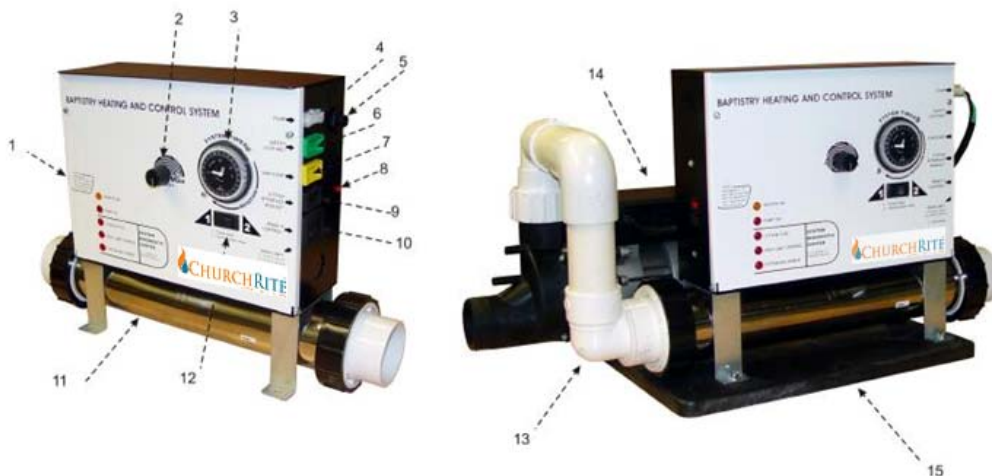

INSTALLATION AND OPERATING CONSIDERATIONS

The equipment control system must be protected from the elements by installing it in a weather-tight enclosure.

The equipment should be installed so that there is safe access for servicing and routine maintenance procedures.

The single-speed circulation pump must be installed below the water level unless it is a self-priming pump.

Connections between the tub and equipment control system should include shut off valves for servicing and only non-metallic pipe should be used.

Connections between the tub and equipment should be done with flex PVC

Operation of your tub during the warm months of the year may cause the temperatures to rise inside the equipment compartment. Due to the extensive insulation of some models it may cause the pumps thermal protection device to automatically turn the pump off for a short period of time (15-30 minutes) to allow the pump to cool down before automatically restarting. This cool down feature will not harm your system but serves to protect the pump from damage. This condition can also be caused by low voltage or by high altitudes where the air necessary for cooling is much thinner.

ELECTRICAL INSTALLATION

A qualified electrician must make all electrical connections to the equipment control box in accordance with the National Electrical Code and in accordance with any local electrical codes in effect at the time of installation. All electrical connections must be made in accordance with the wiring information contained in this manual, or on the back of the field wiring access panel of the equipment control box.

The equipment may be designed to operate at 208-240 volts, 60hz. Connections must be made using copper conductors only. Field provided conductors and circuit breakers or fuses must be sized to accommodate the total amperage load of the equipment.

WARNING - Improper electrical connections or conductor sizing will create the potential for an electrical hazard, and may void the warranty.

CAUTION: Use only approved pressure-type wire splicing or connectors suitable for the size and type of wiring used.

The electrical supply for this product must include a suitably rated switch or circuit breaker to open all ungrounded supply conductors to comply with section 422-20 of the National Electrical Code, ANSI/NFPA 70. The disconnecting device must be within sight, and readily accessible to the user of the tub, but installed at least 5 feet (1.5m) from the tub. The electrical supply for permanently connected equipment controls must also include a suitably rated ground fault circuit interrupter (GFCI) to comply with article 680-42 of the National Electrical Code, ANSI/NFPA 70. Connect a # 8 AWG (8.4mm) solid copper bonding conductor between the equipment control box bonding lug and all other electrical equipment and exposed metal in the vicinity, as may be needed to comply with local regulation.

240 VOLT INSTALLATION - Permanently Connected Units

1. Remove the faceplate from the control box to allow access to the input wiring.
2. Connect input wiring to the terminal block as shown below. A three wire electrical service plus ground is required for a 208-240-volt connection (line 1, line 2, neutral, and ground). Failure to connect a neutral line will cause the control box to malfunction and may void the warranty.
3. Reinstall the control box faceplate.

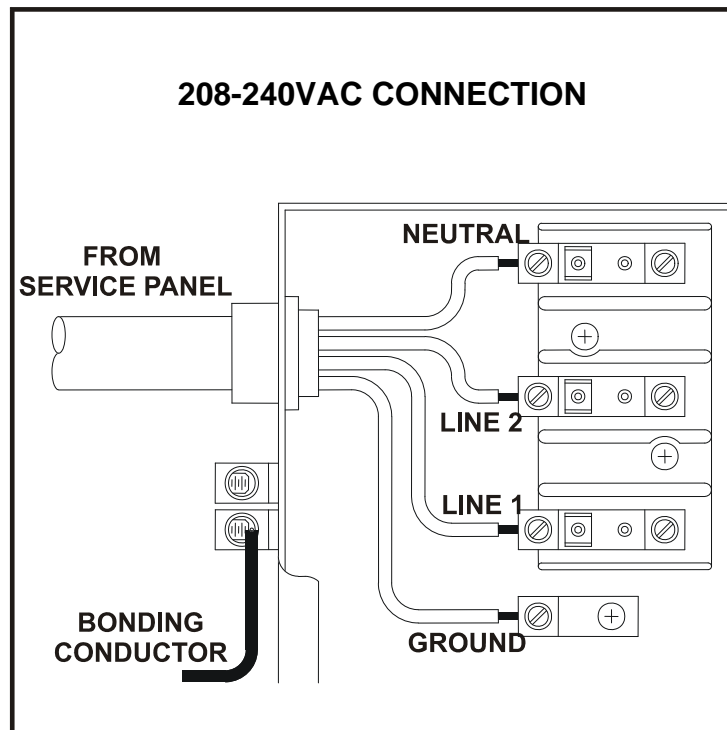

CR COMPONENT CONNECTIONS

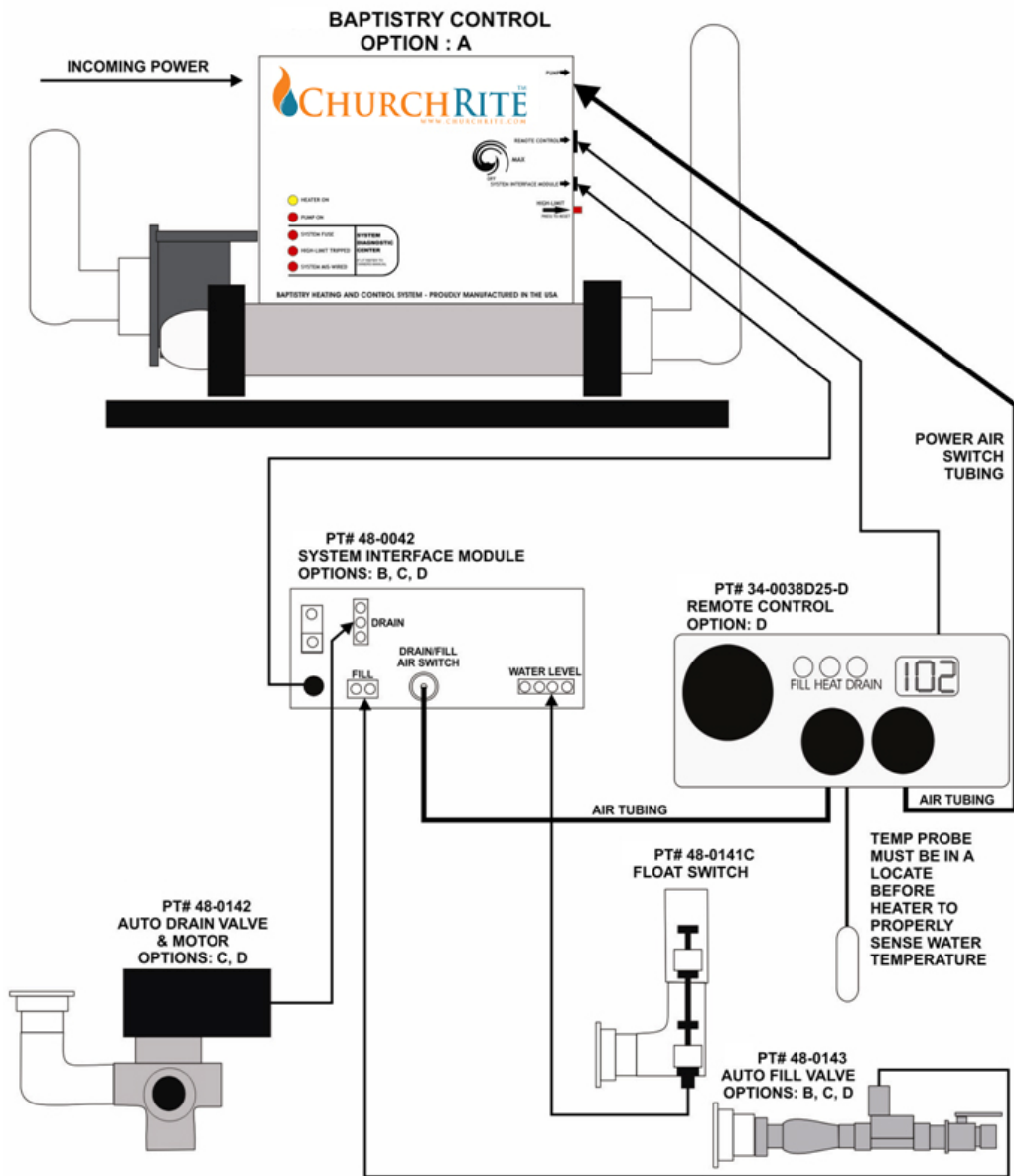

PLUMBING DIAGRAM

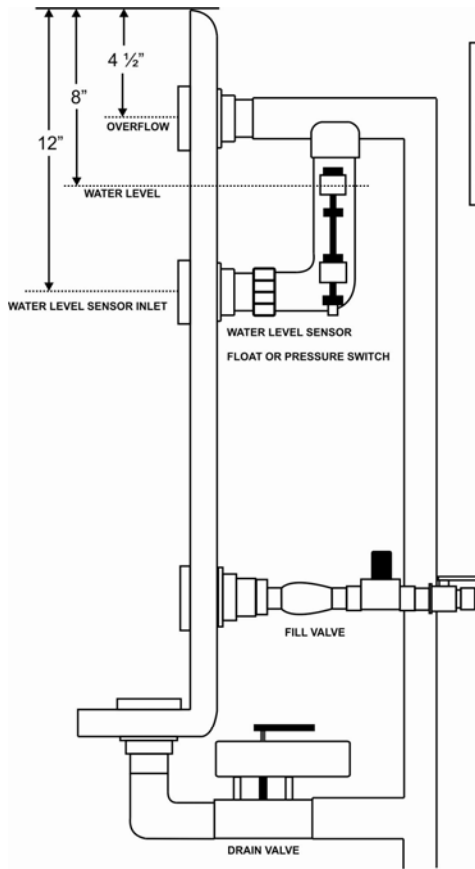

HOLE SIZE CHART

FITTING	PART NUMBER	HOLE SIZE
PUMP INTAKE HEATER DISCHARGE OVERFLOW	42-0004	2 3/8"
AUTO-FILL WATER LEVEL SENSOR	42-0059A	1 13/16"

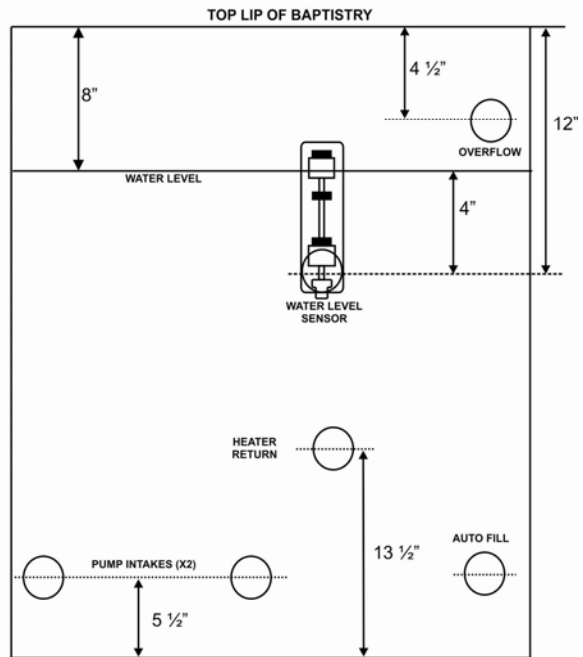

SYSTEM INTERFACE MODULE

TO CONTROL SYSTEM

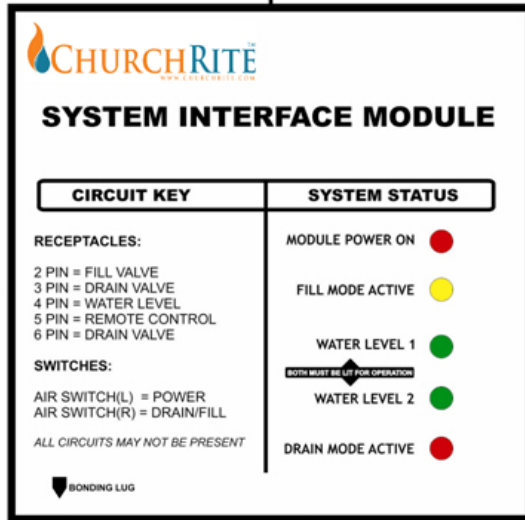

A CIRCUIT KEY IS PROVIDED FOR QUICK & EASY PLUG IDENTIFICATION

SYSTEM STATUS INDICATOR LIGHTS PROVIDE THE USER A VISUAL AID IN THE EVENT OF AN ISSUE WITH ONE OF THE DRAIN/FILL COMPONENTS

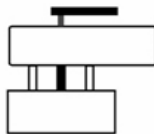

DRAIN VALVE ASSY: Provides automatic drain functionality to the control system



FILL VALVE ASSY: Provides automatic fill functionality to the control system

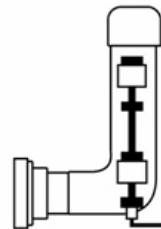

WATER LEVEL SENSOR ASSY: Allows the controls system to monitor the water level inside the Saptistry. May be a float or pressure switch device.

SEE NEXT PAGE FOR IMPORTANT TIPS

PLUMBING AND AUTO-FILL TIPS

PLUMBING TIPS:

- **MEASURE TWICE DRILL ONCE**
- **DRY-FIT PLUMBING BEFORE HOLES ARE DRILLED**
- **FLEXIBLE PVC SHOULD BE USED BETWEEN EQUIPMENT AND BAPTISTRY**
- **ALWAYS USE COMPATIBLE ADHESIVES AND PRIMERS**

AUTO-FILL VALVE TIPS:

- **MAY BE INSTALLED ANYWHERE**
- **VALVE ASSY CAN BE EFFECTED BY WEIGHT, SUPPORT IF NECESSARY**
- **FILL ASSY CAN BE PLUMBED VERTICALLY OR HORIZONTALLY**
- **TO BYPASS FILL VALVE LOSSEN SMALL BLACK SCREW NEXT TO SOLENOID**

AUTO-DRAIN VALVE TIPS:

- **IF SYSTEM IS DRAINING AND FILLING AT THE SAME TIME FLIP TOGGLE SWITCH ON DRAIN VALVE TO OPPOSITE POSITION**
- **DO NOT ATTEMPT TO TURN VALVE BY HAND, PERMANENT DAMAGE WILL OCCURE.**

SKID LAYOUT

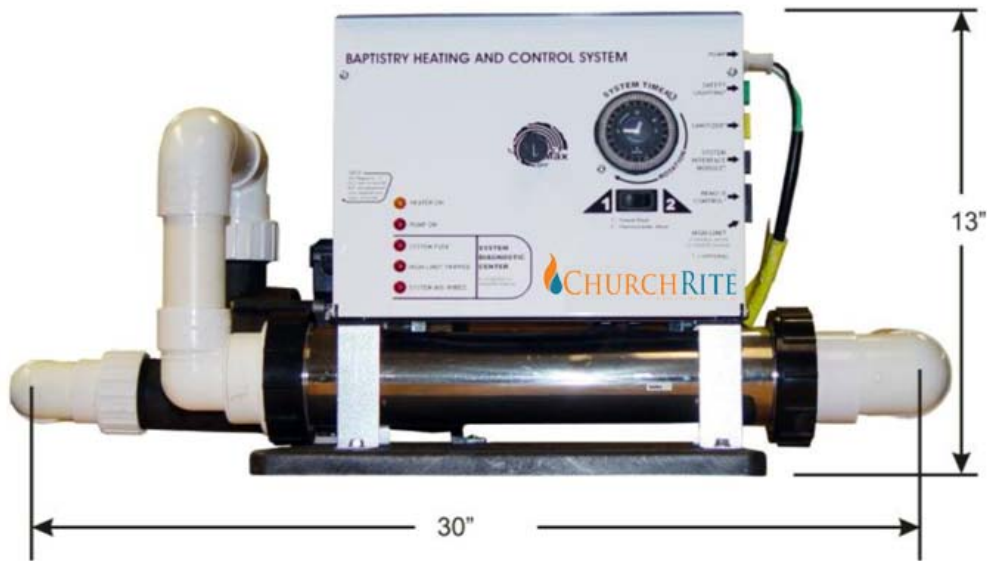

WIDTH = 30"
HEIGHT = 13"
DEPTH = 15"

SYSTEM START-UP

1. Turn the thermostat located on the control box to the off position.
2. Open all water valves, if equipped, on the inlet and/or outlet to allow water to flow into the equipment system.
3. Fill the tub to within 8" to 9" of the top, or as otherwise directed by the manufacturer.

CAUTION: The equipment system must never be operated without water or serious damage to the heater and/or pump may result which can void the warranty.

4. Check all plumbing connections for leaks.
5. With the thermostat in the off position, apply power to the control box.

Note: if the control box is equipped with a ground fault circuit interrupter, it may be necessary to press and release the red GFCI Reset button.

IMPORTANT NOTE: It is most important that the pump be operated for several minutes to insure that all air has been removed from the system before the heater is allowed to operate. Only after full water flow has been established should the thermostat be turned up.

EQUIPMENT DESCRIPTION

CONTROL BOX

The control box contains all the electrical components necessary to operate your tub, it also contains the field wiring compartment. The System Interface Module (DRAIN/FILL CONTROL) Control plugs into the receptacle on the side of the control box.

GROUND FAULT CIRCUIT INTERRUPTER (GFCI)

The GFCI is designed to provide protection against potential electrical shock hazard should a ground fault occur.

The installation of a properly sized ground circuit and bonding circuit is still required as detailed in the electrical installation section of this manual. The GFCI in your installation may be installed at the electrical service panel, a separate sub panel, or built into the control box.

Test the GFCI before each use and at least monthly when the tub is not being used regularly.

Test the GFCI as follows:

1. With the power on, push the test button; the reset button should pop out.

Caution - If the GFCI fails to operate in this manner, do not use the tub until a qualified service technician has corrected the problem.

1. To restore power, push the red reset button in.

THERMOSTAT

Setting the thermostat controls the temperature of the water. The thermostat is located on the front of the control box.

When the equipment is operating, the thermostat will control the heater. Initially, adjust the thermostat knob to the center of the hot range. This setting will cause the water temperature to rise to 95F to 100F (35C to 38C). Do not expect to feel hot water coming from the jets.

The length of time it takes the water to reach desired temperature depends on several factors: water temperature at start, ambient air temperature, tub capacity, relative humidity, type and insulating qualities of a cover and the consistency of electric power applied.

An insulated cover should be kept on the tub at all times that it is not in use. Also, remember that the prolonged use of the air blower and hydrotherapy jets will have a significant cooling effect on the water.

Any graduations on the scale around the thermostat are intended for reference only. They do not reflect the actual water temperature. Remember that a small change on the dial will yield a difference of several degrees, so make small adjustments until you find your preferred temperature. Allow several hours between adjustments for temperatures to stabilize. Use an accurate thermometer to monitor the water temperature.

HEATER

The stainless steel housing contains an electrical heating element and is fitted with a safety pressure switch that monitors water flow.

The heater operates on demand at the power levels indicated in the table below. It will shut off when the thermostat setting is reached or the water ceases to flow.

<u>Model</u>	<u>Heater Voltage</u>	<u>Heater Watts</u>	<u>Breaker Size</u>
CR-6005/T	208-240 V	11.0 kW	60-80A
CR-6000/T	208-240 V	5.5 kW	40-50A

HIGH LIMIT

The purpose of this switch is to shut off the heater if the water temperature within the heater reaches a factory-set, non-adjustable limit. After the water cools sufficiently, push to reset. If the switch trips repeatedly, do not use the tub until the problem has been identified and corrected by a qualified service technician.

SYSTEM INTERFACE RECEPTACLE & MODULE

Provides for operation of Auto-Fill & Auto-Drain options when System Interface Module is installed.

SYSTEM DIAGNOSTIC CENTER

These indicators provide real time diagnostics of the system.

- **HEATER “ON”** – Illuminated whenever the heater is activated
- **PUMP “ON”** – Illuminated whenever the system pump is activated.
- **SYSTEM FUSE** – Illuminated when the main system fuse is blown
 - Possible indication of pump issue.
- **HIGH LIMIT TRIPPED** – Illuminated when the High-Limit safety switch is tripped
 - If the switch trips repeatedly do not use until corrective service is performed
- **SYSTEM MIS-WIRE** – Illuminated when the system has been mis-wired
 - This is an indication the 120V has been sent up the Neutral line and is a protective feature. Have an electrician correct the issue to allow operation.

TIMECLOCK

Provide timer control over heating and filtration cycles. To activate a timed cycle push the teeth on the timer outward, each tooth represent 2 hours of operation. The (2) modes of operation are based on the rocker switch under the timer and are as follows:

1. Timed Heat Mode: The system heats and filters based on the setting of the timer
2. Thermostatic Heat Mode: The pump comes on and off with relation to the thermostat. If a timed cycle occurs outside a heat call the pump will activate to provide additional filtration.

OPERATION

Operating considerations for CR standalone (option A):

1. For initial start up turn thermostat all the way down and fill tub.
2. Insure that tub has water above highest return and open bleed valve on face of pump to bleed air from system.
3. Turn thermostat DOWN and turn on system power, the pump should activate and water should begin flowing. Allow pump to run until all air is purged from the unit
4. Turn the thermostat UP, the heat light on the front the of the CR unit should illuminate.
5. Insure pressure switch is properly adjusted to allow heat function (Indicator will light for heat).
6. Before draining insure that power has been removed from the control.

Operating considerations for CR with Auto Fill (option B):

1. Insure that SYSTEM INTERFACE MODULE (DRAIN/FILL CONTROL) option control is securely plugged into CR receptacle. Install air tubing and air button on the On/Off air switch nipple.
2. Set thermostat all the way down and apply power to unit. If fill valve does not open and begin filling the tub then press the air button supplied one time.
3. Once the unit is full the fill valve will automatically close, the pump will engage and the unit should be ready for heating once air is purged from the system (pressure switch may require some adjustment).
4. Turn the thermostat knob clockwise until the heat engages and set for desired temperature. The pump will continue to run as long as tub is full and power is applied.
5. Before draining unit insure that the auto fill has been deselected (press button once) or that power is removed from CR.

Operating considerations for CR with Auto Fill/Auto Drain (option C):

1. Insure that SYSTEM INTERFACE MODULE (DRAIN/FILL CONTROL) option is securely plugged into matching receptacle and that Auto-Drain valve cord is installed. Install one set of air tubing and air button on the On/Off air switch nipple on the control system and one set on the Fill/Drain air switch nipple on the Interface Module.
2. Set the thermostat all the way down and apply power to unit. If neither drain nor fill valves actuate press On/Off button once. If drain valve starts to open press Fill/Drain button once after valve reaches full open. Once Fill/Drain is in the correct position the drain valve should close and the fill valve should open filling the tub.
3. Once the tub is full the fill valve will automatically close, the pump will engage and the unit should be ready for heating once air is purged from the system (pressure switch may require some adjustment).
4. Turn the thermostat clockwise until the heat engages and set for desired temperature. The pump will continue to run as long as tub is full and power is applied.
5. To drain press the Fill/Drain button once. After the unit is drained press On/Off button once to insure that no inadvertent filling or draining can take place.

Once Fill or Drain is selected you must allow drain valve to travel completely before switching back or the actuator may stick half way requiring power to be recycled

Operating considerations for CR with Remote Control Auto Fill/Drain (option D):

1. Insure that SYSTEM INTERFACE MODULE (DRAIN/FILL CONTROL) option is securely plugged into CR receptacle and that Auto-Drain valve cord is installed. Install one set of air tubing and air button from Remote Control on the On/Off air switch nipple and one set on the Fill/Drain air switch nipple.
2. Insure Remote Control is plugged into receptacle from option control and that both thermostats on CR and Remote Control are set to minimum (fully CCW).
3. Apply power and if no lights appear on Remote Control press On/Off button once. If drain light illuminates wait for valve to finish rotating and then press Fill/Drain button once. If fill light is lit allow unit to fill normally.
4. The unit is full once the digital display appears on Remote Control. Pump will engage and the unit should be ready to heat once air is purged (pressure switch may require adjustment).
5. Turn the Remote Control thermostat clockwise until the heat light on the Remote Control engages and set dial for desired temperature. The pump will continue to run as long as tub is full and power is applied.
6. Once temp is reached the fill light will again appear, heat light will be off and the digital display will display actual temperature. Pump will continue to run.
7. To drain press Fill/Drain once. Indicators should switch from fill or heat to drain and temp display will be blank. Pump will stop.
8. Once the tub is empty press On/Off until all indicators are off to insure no inadvertent filling or draining can take place.

Once Fill or Drain is selected you must allow drain valve to travel completely before switching back or the unit may stick half way requiring power to be recycled

Pressure Switch adjustment:

With pump running and thermostat calling for heat if no heat indicator is illuminated perform the following:

1. Insure flow is moving into tub from equipment and that no air bubbles are present at tub return fitting (if air present open pump bleed valve on face to let air escape).
2. Insert flat tip screwdriver into slot on top of pressure switch and adjust CCW until heat engages (if heat indicator flickers continue adjusting until it remains steady).
3. Once heat indicator remains on steadily adjust the pressure switch knob an additional ½ turn CCW.

Turn OFF power and remove pump output wire (black or white wire) from back of pump motor and insure it is isolated before re-energizing power. Insure that heat indicator does not come on with the thermostat turned up. If indicator does illuminate immediately disconnect power, reconnect pump, and repeat steps 1-3.

PROBLEM SOLVING

Equipment system will not operate:

1. Make sure the Power Air Switch is turned "ON"
2. Check the Ground Fault Circuit Interrupter, if equipped, to see if the reset button has popped out. If it has, press reset button inward. If the GFCI trips repeatedly, contact a service technician to correct the problem.
3. Check the main circuit breaker panel. If the circuit breaker has tripped reset the breaker. If the circuit breaker trips repeatedly, contact a service technician to correct the problem.
4. For cord connected units check the receptacle.
5. Make sure the high-limit has not tripped. Push to reset.

Pump will run but there is no water flow:

1. Make sure all valves are in the open position.
2. Make sure that the filter is clean.
3. Check the suction fittings to make sure that they are not clogged with debris.
4. Check the water level and make sure it is above the jets and at the proper level on the skimmer opening.
5. Check the pump for trapped air. With the pump running, loosen the pump bleed screw to release any trapped air. When there is water flow to the jets tighten the bleed screw securely. You may need to use a sponge to collect the water from the bleed screw.

Pump runs and there is water flow but no heat:

1. Turn the thermostat to a higher temperature setting. Do not expect to feel hot water coming from the jets.
2. Check to see if the high limit switch reset button, located on the front of the control box, has popped outward. If so, reset by pressing inward.
3. Check to make sure that all the valves are open and that there is full flow. Limited water flow may not activate the pressure switch to allow the heater to come on.

The water will not maintain the proper temperature:

1. A thermal cover is required to maintain the water temperature.
2. Turn the thermostat to a higher setting.

Limited Warranty

ChurchRite, Inc. warrants these products to be free from defects in material and workmanship for a period of 1 year from the date of purchase (DOP), under the following provisions:

From DOP to date of installation (Not to exceed 10 working days after DOP), products suspected of failure at time of installation may receive a replacement of component or like product if evaluated by ChurchRite Technical Support with an authorized service professional at the job site. ChurchRite, Inc. will not cover failure due to improper installation, unauthorized modification, negligence, abuse, misuse, or misapplication.

Product failure after installation and up to 30 days from DOP may receive a component replacement if evaluated by ChurchRite Technical Support and an authorized service professional at the job site. ChurchRite, Inc. will not warrant heater elements, heater assemblies with short to ground, fuses, optional controls, or damaged related to freezing, water chemistry, unauthorized modification, negligence, abuse, misuse, or misapplication.

Product failure after 30 days and up to 1 year from DOP will be repaired or replaced at our option. ChurchRite, Inc. will not warrant heater elements, heater assemblies with short to ground, fuses, or damaged related to normal wear and tear, freezing, water chemistry, unauthorized modification, negligence, abuse, misuse, or misapplication.

This warranty extends only to the normal, personal use by the original retail purchaser. The warranty does not cover any commercial use of this product in any way.

Pump seals, O-Rings, gaskets, are not covered by the ChurchRite, Inc. warranty during the first 12 months of the warranty period. Some items furnished by ChurchRite, Inc., such as spa-side controls, may be made by other manufacturers who might have longer warranty periods.

ChurchRite, Inc. will not be responsible for labor incurred in removing, inspecting, repairing, or reinstalling this product. ChurchRite, Inc. will not be responsible for labor incurred for routine maintenance, adjustments, or alterations to the calibration of electrical components.

Resellers of ChurchRite, Inc. equipment may request pre-authorization to return a product that is claimed to be defective by calling 540-488-9400 or faxing support@churchrite.com. The authorized service agent must ship the product freight prepaid to ChurchRite, 510A N. Sheridan St. Corona, CA 92880. Upon repair or replacement the product will be returned to the sender freight collect. When sent to ChurchRite, the product must be accompanied by the sales receipt or other proof of the purchase date as well as the sender's name, mailing address, daytime phone number, and any other information relating to the claim.

Unless state law expressly provides otherwise, ChurchRite, Inc. will only be responsible for repair or replacement of its products that are found to be defective as provided above, and will not bear the cost of any incidental or consequential damages. This warranty gives you specific legal rights and you may also have other rights that vary from state to state.



CHURCHRITE – PO BOX 513 Rocky Mount, VA 24151

WARRANTY REGISTRATION

PURCHASED BY: (PLEASE PRINT)

Name _____

Address _____

City _____ State _____ Zip _____

Telephone () _____

DEALER:

Name _____

Address _____

City _____ State _____ Zip _____

Telephone () _____ Fax () _____

MODEL # _____ Serial # _____

Date Purchased ____/____/____

I have read and accept the warranty terms.

Signature

Date ____/____/____



CHURCHRITE – PO BOX 513 Rocky Mount, VA 24151